



1603 TRAFFIC CONTROL BARRIER GATE AUTO SPIKE SYSTEM

• COMMERCIAL • INDUSTRIAL • MAXIMUM SECURITY



- Mechanically links traffic control auto-spikes to the operator arm
- Optional signal light (red/green) is synchronized with the barrier arm
- Optional warning sign warns drivers to proceed only when spikes are retracted
- DKS patent pending Loop Logic vehicular/pedestrian detection system
- 5 year limited factory warranty on operator
- 1 year limited warranty on tunnel sections, spike sections, and end cap



automatic sequencing
when used in conjunction with slide or swing gate operators



foam padding
available for added protection

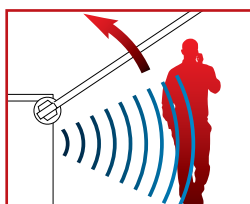

DKS Loop Logic
it's aware -- even when they're not



drive extension
safety design helps prevent operator damage

ACCESS CONTROL **SOLUTIONS**

1603 TRAFFIC CONTROL BARRIER GATE AUTO SPIKE SYSTEM

1 Operator

15.25" W x 43.5" H x 15.5" D
(387mm W x 1105mm H x 394mm D)

- 1/2 HP, 115 VAC *
- Mechanically link traffic control auto-spikes to the operator arm.

* High Voltage Kit: Allows the operator to be powered from 208, 230, 460 or 575 source voltage.

2 Tunnel Section

surface mount

20" W x 2" H x 18" L
(508mm W x 50.8mm H x 457.5mm L)

- Drive extension (18" (457mm)) is required to connect the operator to the spike section(s).
- Tunnel section provides an extended connection from the operator to the spike section(s).
- Tunnel sections can be mixed to create the desired length and are used when the 1603 is set back from the curb.

3 Spike Section

surface mount

20" W x 2" H x 36" L
(508mm W x 50.8mm H x 914mm L)

- Combination of spike sections / tunnel extensions should not exceed 12 feet in width.

4 End Cap

20" W x 2" H x 7" D
(508mm W 50.8mm H x 177.8mm D)

- Provides a smooth end to the spike section.

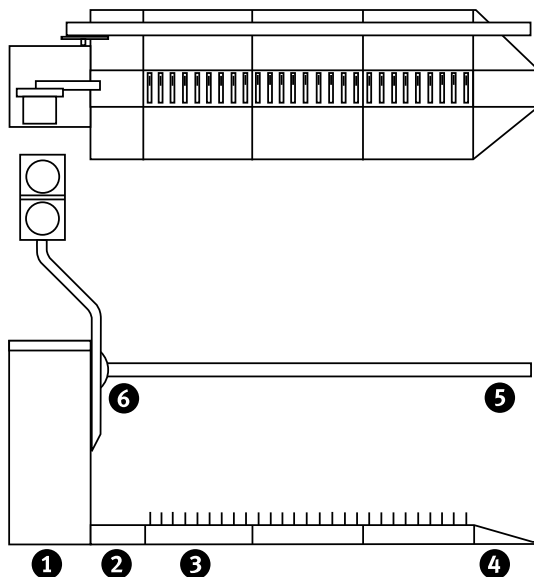

5 Barrier Arm

- 14-foot round (3") aluminum arm painted white with red/white visibility tape, MUTCD compliant.

6 Barrier Arm Hardware Kit

7 Signal Light (option)

9.75" W x 21" H x 14" D
(247mm W x 533mm H x 355mm D)

(includes lens shield)

- 115 VAC
- 8" Red and Green lenses
- 8000 hour / 67 watt traffic bulbs
- Mounting bracket for easy attachment to the 1603 operator
- 1 year limited warranty

Warning Sign (option)

24" W x 24" H x 8" D
(610mm W x 610mm H x 203mm D)

- 115 VAC
- Two 20 watt fluorescent lamps and one 150 watt flood lamp
- Light sensor turns sign on at dusk, off at dawn
- 2 year limited warranty

Traffic signal and/or warning sign must be used with this system.

WARNING:
Traffic control auto-spike systems are not intended to be used in areas where vehicular traffic is uncontrolled or crosses over the spikes at an angle other than 90°, or where traffic speeds may exceed 5 MPH. Speed bumps, warning signs and/or traffic signals must be used with auto-spike systems.

Technical Features

Mechanical

Primary Reduction is provided by a worm gear reduction system running in a continuous oil bath

G90 galvanized steel housing, painted white rated NEMA 4x

Fail-secure mechanical release method, and hand crank allows lowering of the spikes in the event of a power outage

Options

DC powered convenience open system that will cause the arm to raise automatically in the event of a power outage

Heater/fan kits for extreme weather conditions

Loop Logic vehicular / pedestrial safety system: The system reverses barrier arm if person is detected, and lowers barrier arm if unauthorized vehicle enters. Additional protection to help prevent inadvertent accidents

Electrical

Magnetic electronic limit controls

Auto-close timer 1-23 seconds

Up input memory buffer

Down memory option

Multiple up commands

Ports for plug-in open (up) and reverse (down) loop detectors. DKS plug-in detectors only

Ports for plug-in loop detectors

Auto-sequencing in conjunction with slide or swing

Built-in power On/Off switch

115 VAC convenience outlet for accessory transformers

Gate Tracker™ reporting output provides operator data to access control system (DKS 1833, 1835, 1837 or 1838 only)

Miscellaneous

Environmental: 10°F to 115°F (-12°C to 46°C)

Thermostatically controlled heater kit recommended for colder environments



Distributed by:

SECURE LANE LLC
www.secure-lane.com
www.barriergatearm.com
(520)780-9751

Access Control Solutions since 1948

MEMBER:



DOOR KING, INC.

120 Glasgow Avenue, Inglewood, California 90301 U.S.A.
Tel: 310-645-0023 FAX: 310-641-1586 www.doorking.com

© 2015 All Rights Reserved. Product specifications may change without notice.
Rev.3/15